

TORK[®] Hydraulics

Heat Exchanger Series

AH1417T Series Air Cooler

Symbol

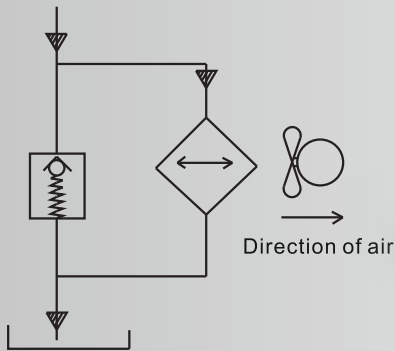

Performance curve

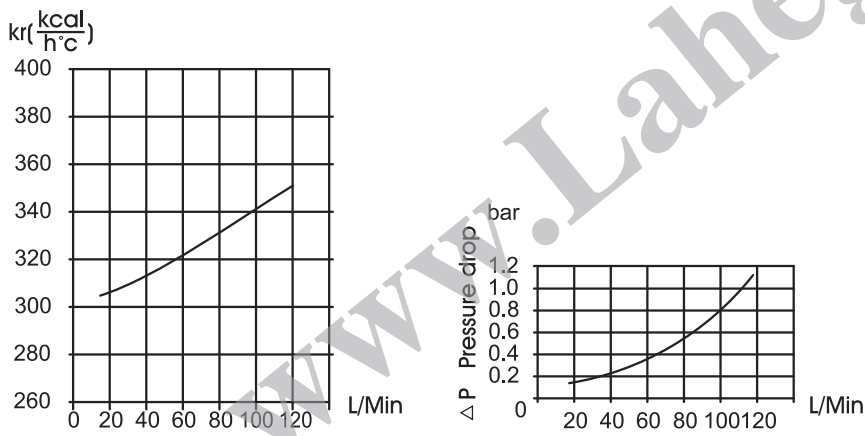

Technical data

Model	Voltage	Max. flow rate (l/min)	Max. working pressure (bar)	Consumed power (W)	Speed (rpm)	Noise (db)	Weight (kg)
AH1417T	DC12V	150	35	120	2000	60	21.2
	DC24V				2420		
	AC220V (50Hz/60Hz)			129	1400		
	AC380V (50Hz/60Hz)						

AH1417T series air cooler dimensions

Unit: mm

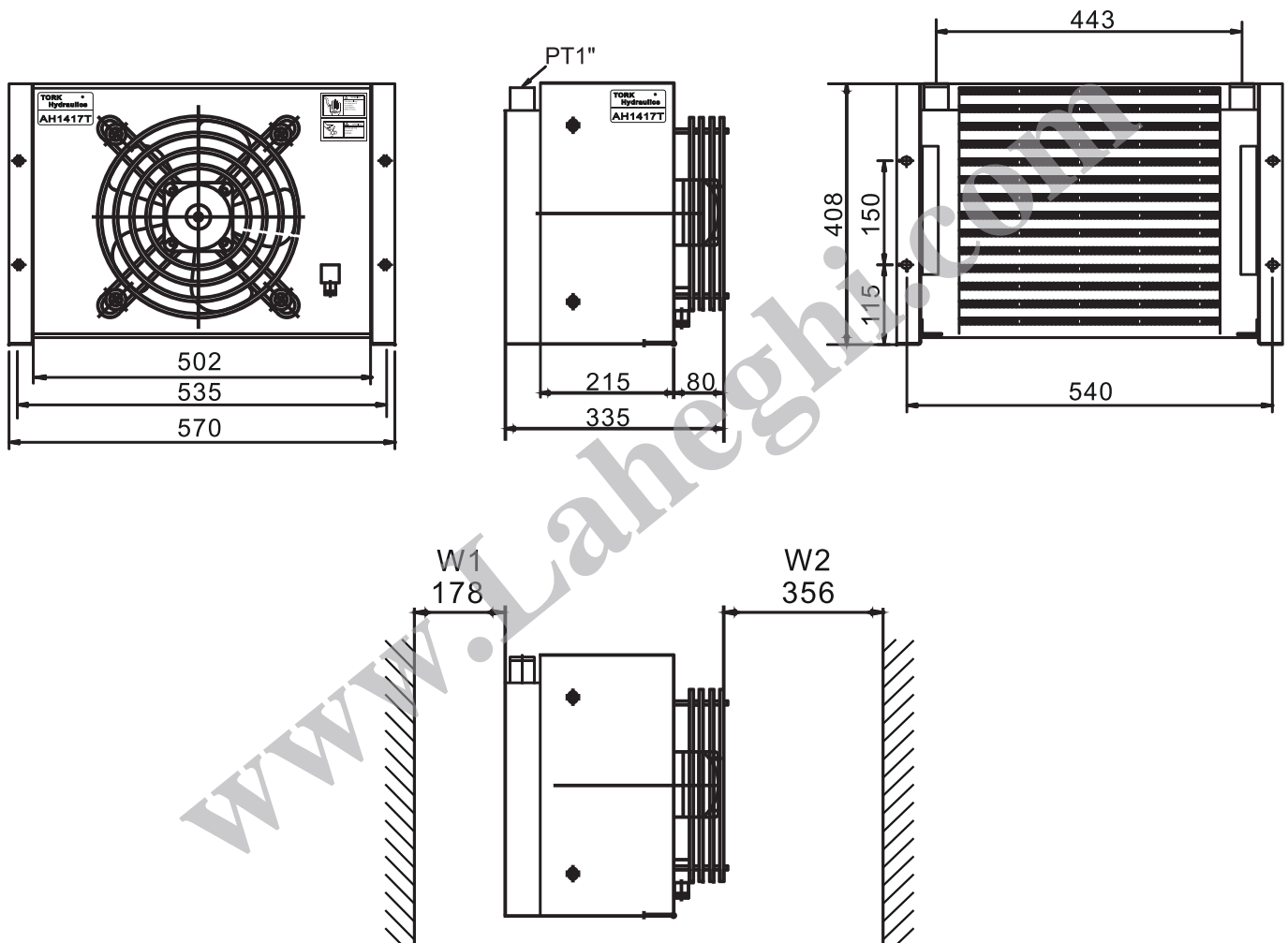

W1 is the min. distance between air inlet and obstacle

W2 is the min. distance between air outlet and obstacle